

BILDON 2000 TIMBER FASCIA SYSTEM
 MANUFACTURED AND SUPPLIED BY TOTAL FASCIA LTD.
 OCTOBER 2008

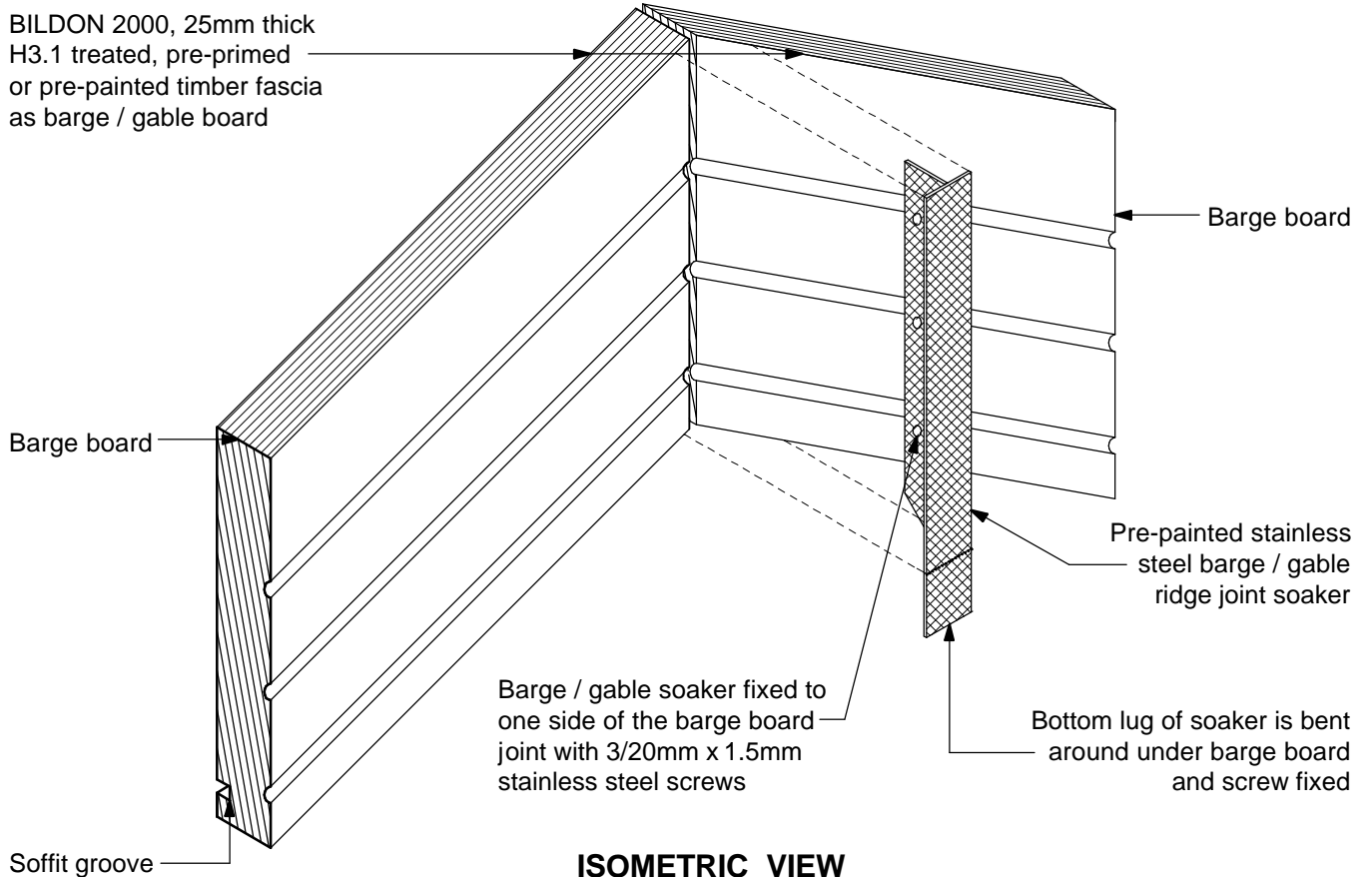

**ISOMETRIC VIEW
 (soaker shown exploded)**

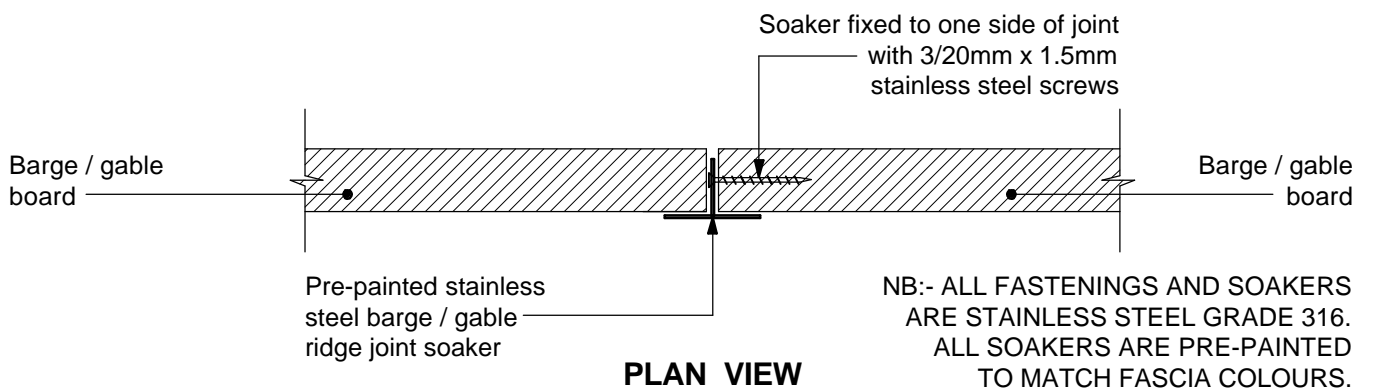

PLAN VIEW

GABLE / BARGE JOINT AT RIDGE DETAIL

(TYPICAL DETAIL: CHECK DIMENSIONS AND MEASUREMENTS BEFORE COMMENCING WORK AND INFORMATION ON THIS SHEET SHOULD BE READ IN CONJUNCTION WITH OUR INSTALLATION REQUIREMENTS AND BROCHURE)